



Process Advanced Filtration Division
 2340 Eastman Avenue
 Oxnard, CA 93030
 Phone (805) 604-3400
 Fax (805) 604-3401

EP7640-BS01-H7 UF Membrane

Description

PVDF Spiral membrane
 FRP outer wrap
 One end seal - ATDs both ends

Dimensions

Diameter (A)	7.48" (190 mm)
Overall Body Length (B)	40.0" (1016 mm)
Permeate Tube ID	1.285" (32.6 mm)
Membrane Area	278 ft ² (25.8m ²)
Weight	40 lb (18.2 kg)

Recommended Operating Parameters

Feed	63 - 77 gpm (238-291 lpm)
Inlet Pressure	40-65 psig (2.7-4.41bar)
Outlet Pressure	15-40 psig (1.0-2.7 bar)
Delta Pressure	25 -35 psig (1.7-2.4 bar)
Max Temperature	120°F (49°C)
Max pH Range	2-11 operating 2-12 cleaning

Permeate Flow on Fresh Lab Paint Baths

2.5 to 4.0 gpm (9.5 – 15.1 lpm)

Housing

Newer 2VUF80 PVC and SS Series

Rev 07/10

Engineered for Electrocoat Applications

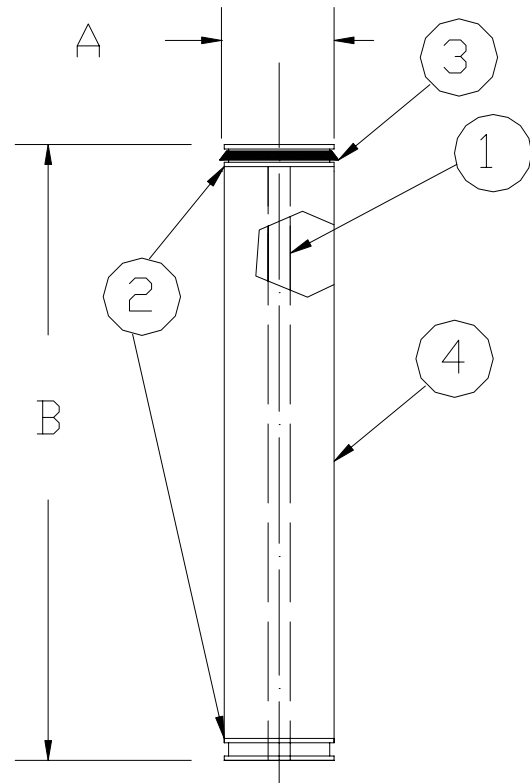

Item	Description
1	Permeate Tube
2	ATD/Seal Carriers
3	Brine Seal (P/N BS-76)
4	Element Body

