

PROPOR[®] 50 & 25

Disposable PES Membrane Syringe Filters

product information

PROPOR 50 & 25 are disposable filters highly suitable for the filtering of aqueous and proteinaceous solutions.



High flowing and low binding these filters have a range of connection formats offering a convenient and time saving method for connection. Designed primarily for use with syringe they eliminate the need for expensive reusable holders and ensure perfect sealing of the membrane every time. Their robust design allows for repeatedly autoclaving where multiple batch use is required and has been validated.

Liquid Applications

PROPOR 50 & 25 contain a hydrophilic Polyethersulphone (PES) membrane encapsulated in a robust polypropylene housing providing validated 0.10 and 0.20µm sterilizing grade filtration, with options for 0.45µm and larger micron ratings for bioburden reduction or clarification applications.

Scaleability

The filter membrane used in the construction is also applied to the larger area formats in **domnick hunter's PROPOR** range of products simplifying the scale-up process.

domnick hunter's PROPOR 50 & 25 brings the following benefits:

- ❑ **High flowing**
 - ◇ Rapid sample preparation.
- ❑ **Hydrophilic PES membrane and polypropylene componentry**
 - ◇ compatibility with wide range of solvent systems.
- ❑ **Robust thermally bonded construction**
 - ◇ reliable operation.
- ❑ **Inlet and outlet connection options**
 - ◇ select to suit application.
- ❑ **Designed for scaleability with the domnick hunter PROPOR range of filter products**
 - ◇ simplified product selection and validation when higher capacity is required.
- ❑ **Multi-cycle Autoclavable**
 - ◇ economic multi-batch use (when application permits)

Materials of Construction

Filter Membrane : Polyethersulphone (PES)
 Support Layers : Polyester
 Housing : Polypropylene
 Assembly method : Thermal Weld

Recommended Operating Conditions

Maximum Operational Differential Pressure:
 3.0 barg (45 psig) @ 20°C

Effective Filtration Area (EFA)

50mm - 14.5 cm² (2.25 in²)

25mm - 3.6 cm² (0.56 in²)

Sample Volumes:

25mm - < 100 ml 50mm - < 400 ml

Water Flows: (ml/min/cm² @ 1000mbar Δp (1cp))

0.10 μm: 4 0.20 μm: 35 0.45 μm: 60

Biological Compatibility

PROPOR 50 & 25 products are manufactured from materials suitable for drug and food product contact as identified in appropriate sections of FDA 21CFR177. Polymeric materials used in the construction also conform to the requirements of USP Plastics Class VI – 121°C.

Integrity Testing

Minimum defined bubble points for each grade have been specified as:

Micron Rating	0.10 μm	0.20 μm	0.45 μm	
Wetting Fluid	IPA	Water	Water	
Bubble Point (min)	2350	3760	2750	(mbar)
	26.9	54.6	39.9	(psi)

Membrane used in the construction of devices has been validated in accordance with ASTM F838-83 methodology to bacterial challenge using

- *Acholeplasma laidlawii*,
- *Brevundimonas diminuta*
- *Serratia marcescens*

for 0.10, 0.20 and 0.45μm ratings respectively.

Steam Sterilisation

PROPOR 50 & 25 are autoclavable at up to 130°C.

Lot Traceability

Each **PROPOR 50 & 25** are etched with a lot number for identification and traceability.

Manufactured lots are sample tested for device strength, membrane integrity and air flowrate characteristics.

SELECTION

domnick hunter Ltd. **PROPOR 50** filters can be readily specified by unique code numbers which can be easily built up for ordering and identification purposes. To specify the filter you require, simply insert your particular requirements in the relevant boxes of the master code shown below.

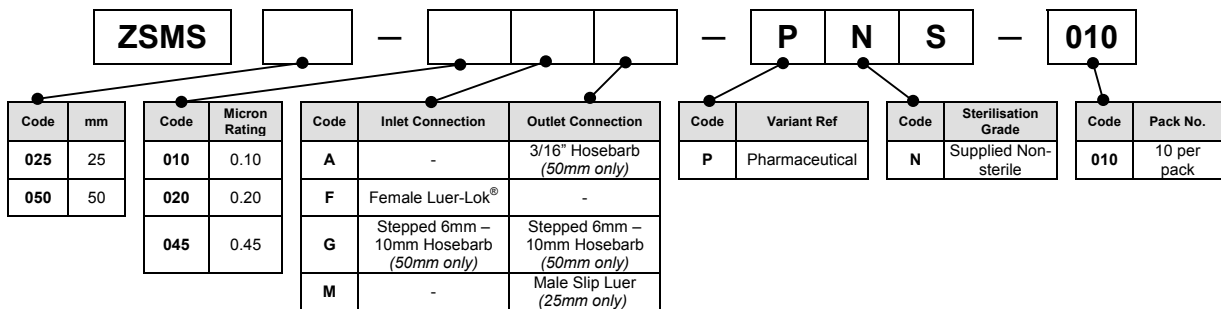

For other product sizes, micron ratings and connection formats please contact your **domnick hunter** outlet

Luer-Lok is a registered trademark of Luer-Lok Corporation.



domnick hunter

PROCESS FILTRATION

Durham Road, Birtley, Co. Durham
 England DH3 2SF

Tel: +44 (0)191 410 5121

Fax: +44 (0)191 410 5312

E-mail: process@domnickhunter.com

WebSite: www.domnickhunter.com

Copyright **domnick hunter limited** 2003

Publication Reference: PD34/05/03

Stock No.: 179510041 Rev 1.0

domnick hunter limited has a continuous policy of product development and although the Company reserves the right to change specification, it attempts to keep customers informed of any alterations. This publication is for general information only and customers are requested to contact our Process Division Sales Department for detailed information and advice on a product's suitability for specific applications. All products are sold subject to the company's standard conditions of sale.